

## Q-Mark Fire Door installation guidance instructions

Read through the Instructions thoroughly before commencing any work

Check the structural opening size against the door set, it is recommended that there is a 5mm clearance gap all the way around the outer edge of the frame.

Work in accordance with the sites manual handling policy, it is advised that two persons lift, move and position the door set.

Figure 1

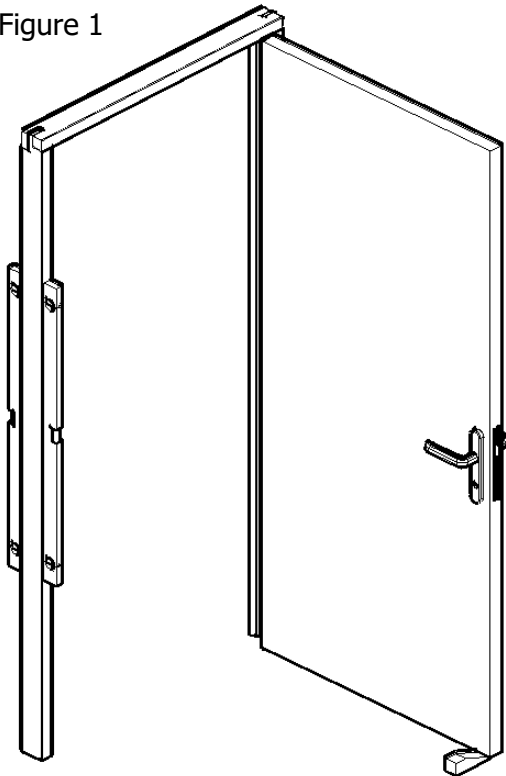

1255

Place the door and frame in structural opening and then open the door 90 degrees. Position a suitable packer beneath the opening edge of the door leaf, ensure the hinge side of the frame is plumb to both internal and external faces using a spirit level.

If the floor is not level, fit packers under the jambs.

Pack the hinge side of the frame ensuring the frame is plum and square, check that the leg is not bowed.

Figure 2

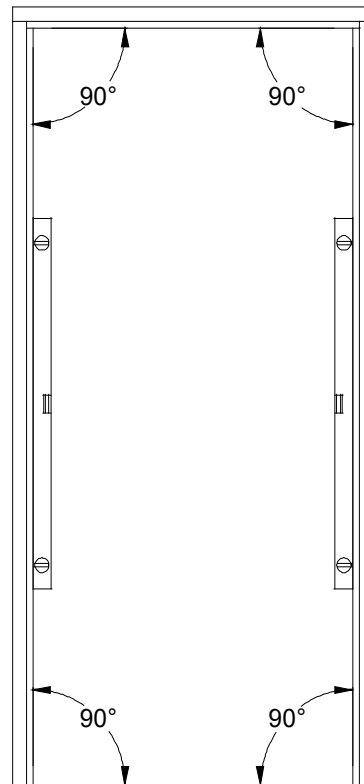

Page 1 of 6

The positioning of installation fixings in height must be planned to avoid conflicts with the lock keeps, draught and intumescent fire seals.

Maximum of 600mm centres between fixings.

Figure 3

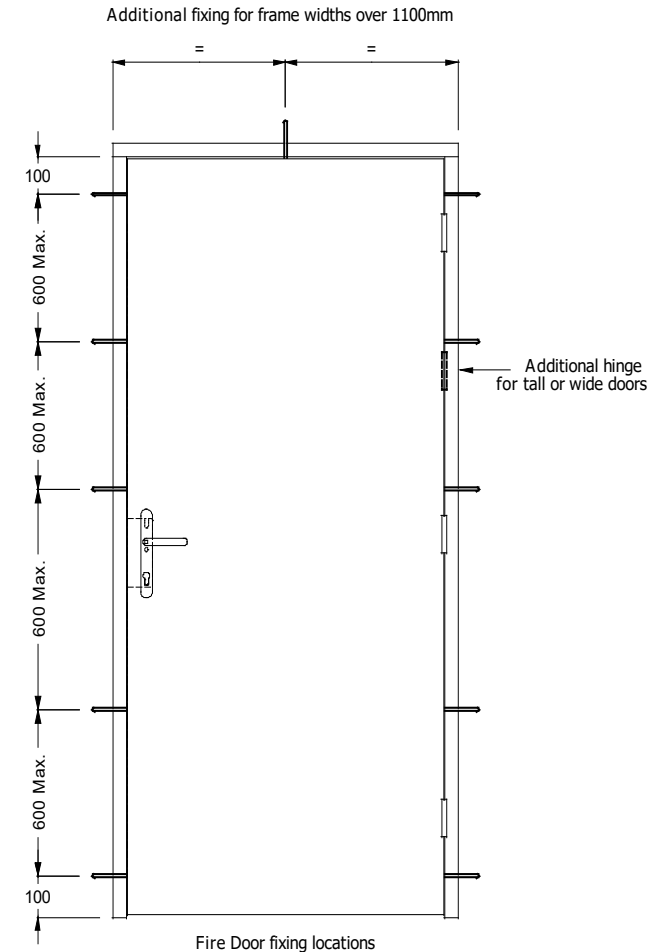

Form 35-10 (26.07.2022)

Ensure that frame is plumb, before fixing the hinge side of the door

Drill through the frame on the hinge side so that the fixings are in the intumescent groove, the fixings need to pass through the horse shoe packers.

Appropriate Steel Fixings for the frame thickness and that suits the wall substrate must penetrate a minimum of 40mm as Figures 4a/b

Hardwood & plasterboard packers can be used on FD60 fire rated doors, plastic horseshoe packers can be used on FD30 fire rated doors

Figure 4a FD30 frame

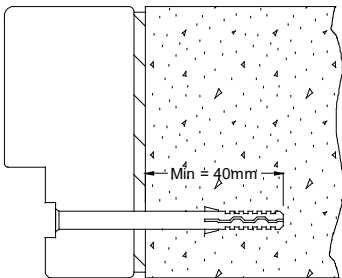
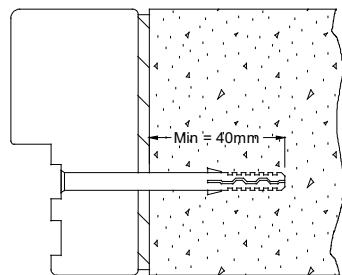

Figure 4b FD60 frame



Note: See Sealing Structural Openings

Drill through the frame into the wall as shown in Figure 5 below, then loosely secure each frame fixing into the wall, then tap the horse shoe packers into position, before fully securing each frame fixing check that the frame has not moved out of square and is still plumb.

Figure 5

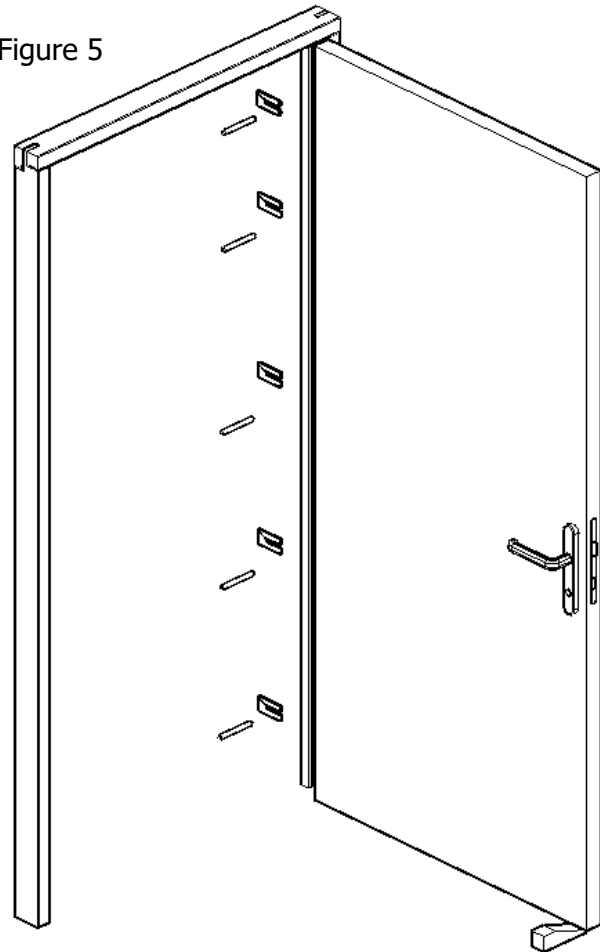

Drill through the frame on the lock side at the top of the frame as below in Figure 6 (see Figure 3 for dimensions), secure with a frame fixing and horse shoe packer.

Check that the frame is square and plumb as shown in Figure 1 and Figure 2

Figure 6

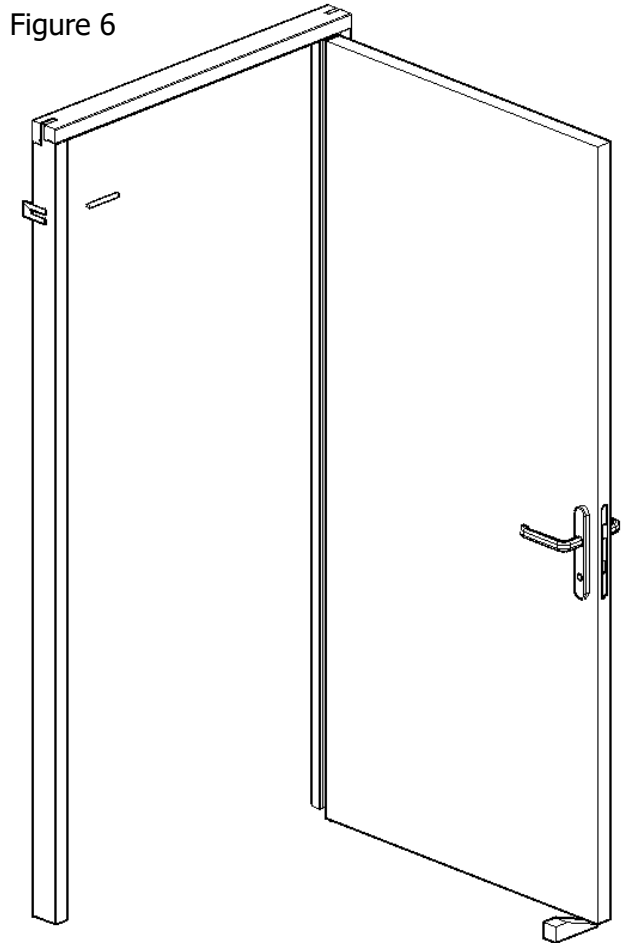

With the door almost closed, align the edge of the door with the edge of the frame, so that the gap is the same from the top to bottom of the door.

Figure 7

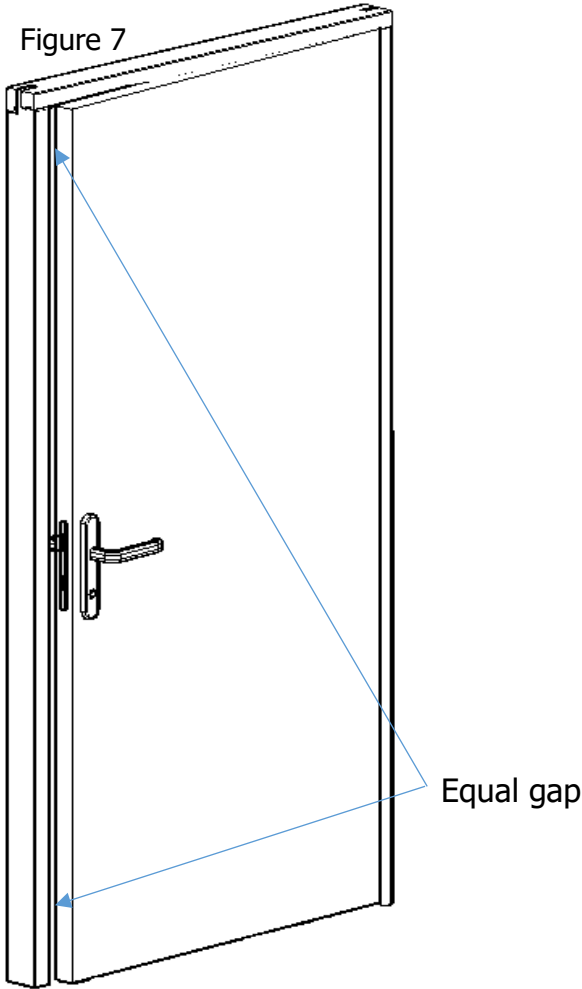

Repeat this procedure after each frame fixing point, this will allow for any possible bow or twist of the door leaf.

Figure 8

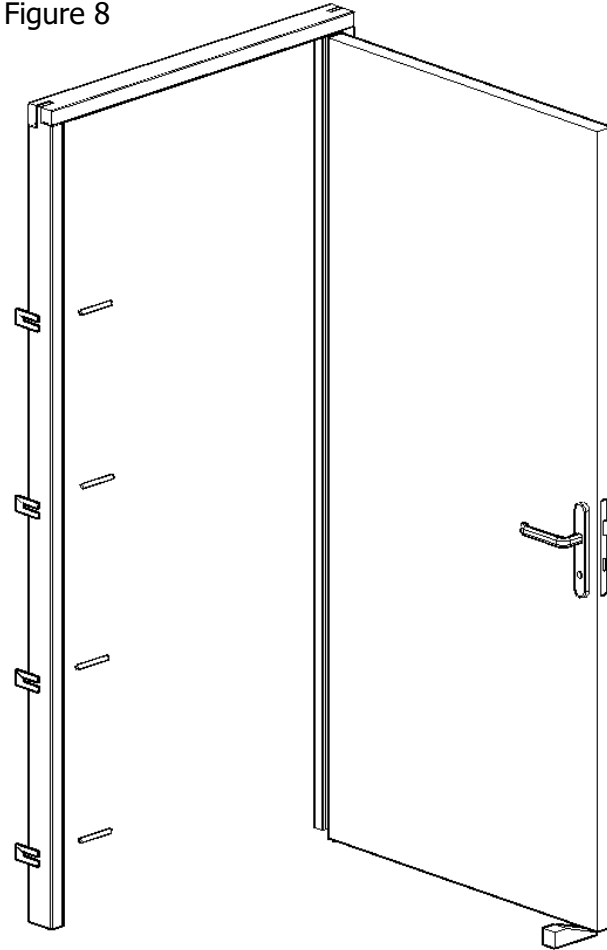

When all fixings are secured, the nominal gaps should be as shown in Figure 9

If fitting a lock (Certifire CE marked) ensure the relevant intumescent is fitted as per manufactures instructions.

Check the operation of the lock  
Adjust the lock keep to ensure that the lock latches correctly

Figure 9

See below for permitted door gaps with top & side gaps having a tolerance of +/- 1mm

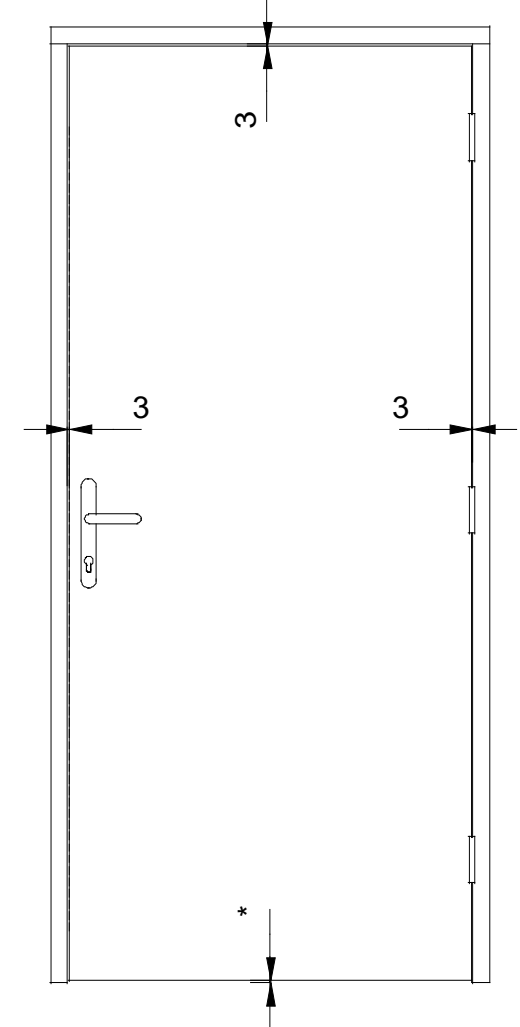

Apply an intumescent mastic sealant between the frame and the structural opening all around the frame.

\*Note smoke rated doorsets must have drop seals fitted

Doorset configurations allowed dependant on the hinge type and the product Field of Application

Single Leaf single acting

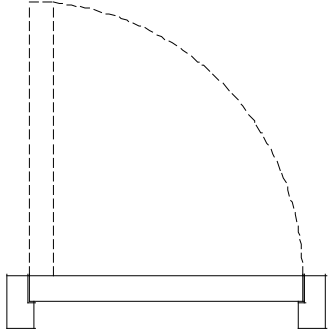

Double Leaf single acting

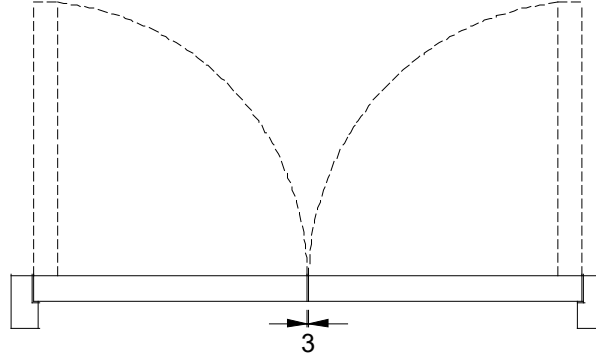

Single Leaf double acting

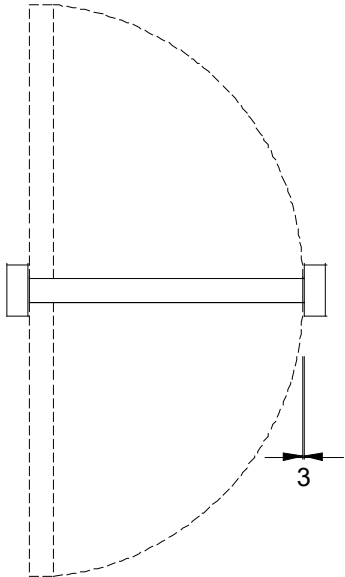

Double Leaf single acting

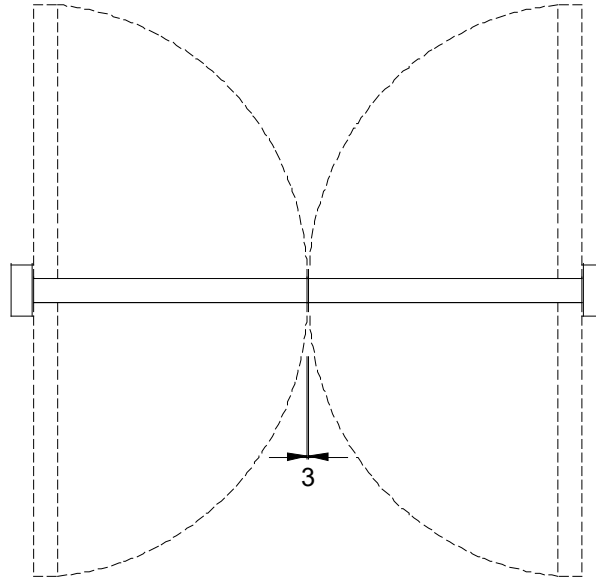

At the meeting stiles of double doors, the flipper seal must touch the opposite door to create a smoke seal

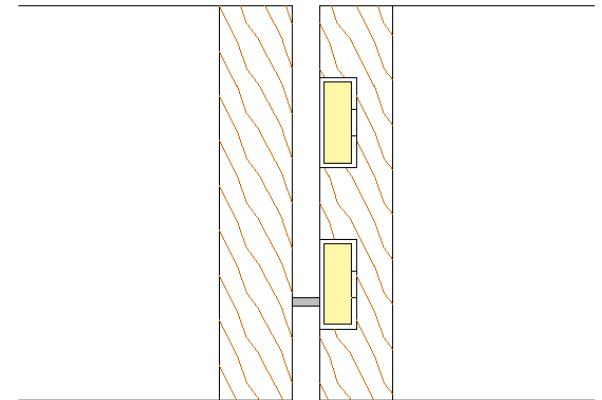

## Sealing Structural Openings

The door frame to structural opening must be protected by using one of the following methods and any shown in BS 8214:2016 clause 9.4.1 tables

1. Joints up to 10mm must be sealed on both sides as shown, with a 10mm depth of acrylic intumescent mastic. 15mm thick architraves overlapping at least 15mm each side
2. Gaps between 10mm and 20mm must be tightly packed with mineral fibre/ceramic fibre capped on both sides with a 10mm depth of acrylic intumescent mastic
3. Joints up to 20mm must be tightly packed with mineral fibre/ceramic fibre capped on both sides with a 10mm depth of acrylic intumescent mastic, with 15mm thick architraves overlapping at least 15mm each side
4. Timber based or non-combustible sub-frame up to 50mm thick, with gaps up to 10mm between components filled on both sides with 10mm depth of acrylic intumescent and 15mm thick architraves overlapping at least 15mm each side

Architraves are to be manufactured from the same timber as the doorset frame or of a density and approved species that meets the required fire rating

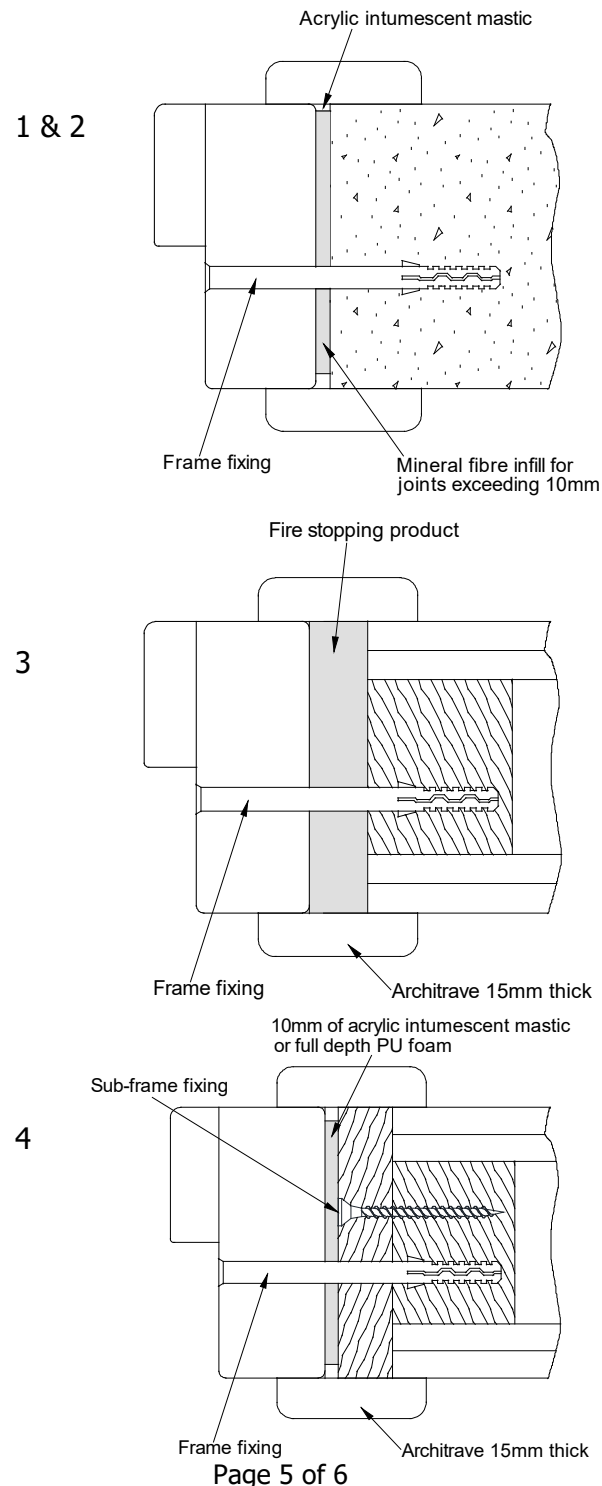

Acrylic intumescent, must be tested to EN 1366 part 4, BS 476 Part 22, BS 476 part 20 or BS EN 1634-1. Integrity to be as fire doorset or higher as stated in BS 8214:2016 clause 9.4.2

Mineral fibre/ceramic fibre to meet Euroclass A1 or A2 to EN13501-1 and heat resistant to at least 1000° C.

Note: Expanding foam is **only suitable for FD30 fire doors**, specification of fire foam must be as per BS 8214:2016 clause 9.4.2

Q-Mark Fire Rating Identification Plugs are fitted on the edge of the door, below the top hinge

Fit the intumescent strips which are supplied loose into the frame grooves, ensure that the intumescent is cut and profiled neatly around the keeps and hinges, the intumescent strips must be fitted to obtain the products fire rating

If a Drop Seal is fitted adjust as required by adjusting the end button on the drop seal

Fit a face fix overhead door closer as per manufactures instructions, and integral door closers if required are to be supplied and pre-machined by Pendle Doors.

Integral door closers must be fitted with the intumescent kit if supplied with the closer

All Door Closers, Hinges and Locks must be CE marked

Locks, Keeps, Shoot Bolts and Butt Hinges must be fitted with intumescent kits

Note: Modifications or additions are not permitted to door assemblies and doorsets

FD30 - Door lipping can be trimmed, if door edge has no ironmongery or product preparation (contact Pendle Doors for details)

FD60 - Door lipping can be trimmed, if door edge has no ironmongery or product preparation (contact Pendle Doors for details)

FD90 - No trimming allowed

FD120 - No trimming allowed

Note: See Sealing Structural Openings

Q-Mark plugs denote the period of fire resistance, the approval of elements including intumescent and glazing

Q-Mark plugs are positioned below the top hinge if fitted or prepared for.

If a door blank is supplied with no hinges or preparation the plug or plugs are fitted centrally in the top edge of the door

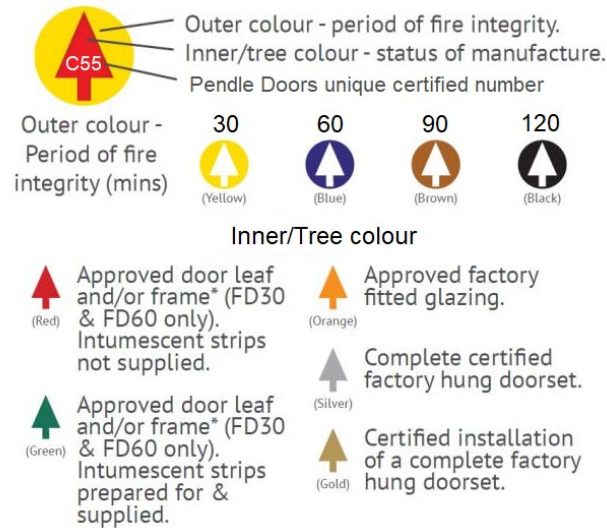

Note: A Gold inner can only be supplied and fitted by a Certified Q-Mark installer

Example shows a FD30 door with a yellow plug with a silver insert stating the door is hung in a frame with ironmongery fitted, also a yellow plug with an orange insert stating the door has a glazed vision panel

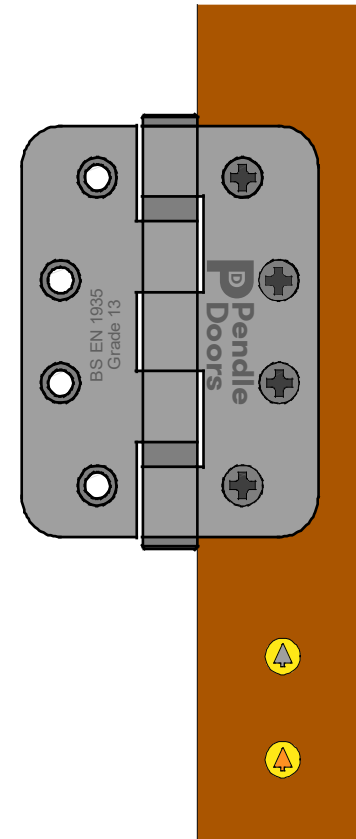

**Note: Pendle Doors does not take any responsibility, or endorse the use of any product(s) in the fitting of doorsets.**

**Pendle Doors strongly recommends that installation of fire doors should be carried out by qualified installers**